

1. Scope

This material standard covers the requirements for manufacturing and supplying a precast reinforced concrete sloping bulkhead having the dimensions and features indicated in Figure 1.

2. Material ID Number

The following vault MID's shall conform to the corresponding diagram dimensions:

2.1 VAULTS AND VAULT ASSEMBLIES

Material ID	Description	Section
780735	4'10 x4'10, with 6" x 48" rise	
1002296	5'8 x10'6, with 6" x 48" rise	8.1

3. Reference Standards

Reference is made in this material standard to the following standards, the latest editions, amendments, and supplements of which shall apply, unless otherwise stated in this document or in associated purchasing documents:

ASTM A615	<i>Specification for Deformed and Plain Billet-Steel Bars for Concrete Reinforcement</i>
ASTM C33	<i>Specification for Concrete Aggregates</i>
ASTM C150	<i>Specification for Portland Cement</i>

4. Concrete and Reinforcing Bars

The bulkhead shall be manufactured of concrete meeting a minimum compressive strength of 4,000 psi after 28 days. The concrete shall meet the requirements of ASTM C150 and C33. Reinforcing bars shall meet the requirements of ASTM A615.

5. Lifting Inserts

The bulkhead shall be equipped with four lifting inserts as illustrated in Figure 1. The lifting inserts shall be 3/4" diameter threaded type. Lifting inserts shall be protected with removable plastic caps.

6. Concrete Finish

All of the exposed surfaces of the bulkhead shall have a smooth or brush finish. All upper corners and edges shall be rounded (tool finish or molded).

7. Shipping

Each bulkhead shall be delivered on an open flatbed to the job site or storage location designated by the District when an order is placed. Bulkheads shall be shipped in an upright position so they do not have to be flipped to install.

8. Dimensions

8.1

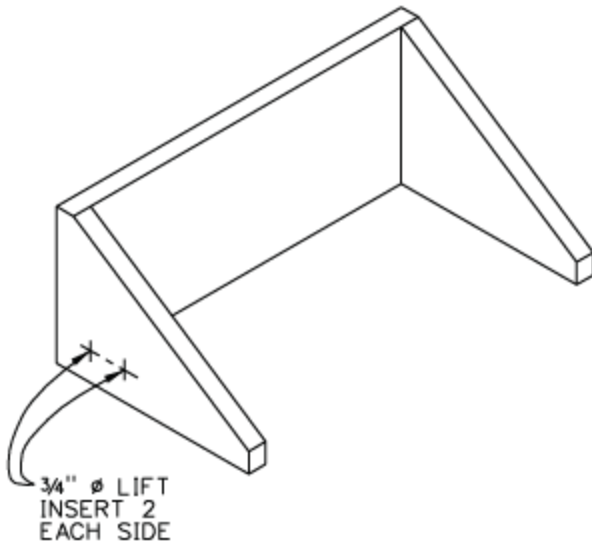

FIGURE 1

